

Brough
Superior

Since 1919

PENDINE
Sand Racer

LIKE A BREATH
OF ADVENTURE ON THE SAND OF PENDINE





In 1927, a sensual and elegant panther is born. Its name, SS100 Pendine Sand racer in tribute to Wales' famous beach. Georges Brough, its creator, guarantees 110 mph speed.

Pendine, the records beach has seen Brough Superior win famous races and it is not about to stop with this moto.

This beauty is unique in many ways: a face shield that helps protect the pilot from sand, an engine 981 cc ohv JAP KTOR 8/45 with four cams, a fuel tank, mounted on steel strips, held by three wrap-around bands.

Exceptional motorcycle, exceptional driver, Jack Carr, the man from Yorkshire, is the greatest sand racer Brough has ever had. In the 1930s, he won many races on the beaches of northern England riding the new Pendine. In 1931, back to Pendine Sand, he won the 50-mile and 100-mile races.

2013, rebirth of a legend. Pendine sand was longing for Brough, that's when, Brough Superior came in with replica of SS100 Pendine. Eric Patterson rode it and Henry Cole captured the event.







Brough Superior's team has created a panther with sensual curves, worthy of its big sister, the super sport 100 model. This new moto's name is Pendine Sand racer tribute to Wales' famous beach.

She likes to participate in sand races but will also take you on other paths.

A PURE HAPPINESS, 2 VERSIONS EXIST.

- The Sport version, for adventurers who appreciate the traditional charm of Brough's classic motorcycles.
- The Desert version, inspired by the dirt bikes of the 70s, for adventurers drunk with freedom and lovers of wild spaces to tame.

On both models you will find:

- High-end exhaust system
- Brake discs 320 mm in diameter (x2)
- Machined aluminum fork and swingarm with SDS system
- Machined aluminum wheels -17" & 19" (16 spokes)
- High and large handlebars





C. Badajoz
↑ Centre Comercial P
↑ C-31 Girona
↑ Av. Meridiana
↻ Can D...
Av. ...
Pl ...







Located in Wales, on the shore of Carmarthen Bay, Pendine Beach, named after the small village, nearby, is a long, flat and hard strip of sand.

Supported by the dunes, it extends from Gilman Point to Laugharne Sands for about 7 miles.

Due to its configuration, it was the perfect track for motorized races at the beginning of the 20th century, and several speed records were set there.

Among the famous runners, Jack Carr, the Yorkshire man, is the greatest sand runner Brough has ever had. In the 1930s, he won many races on the beaches of northern England with the new Pendine. In 1931, at Pendine Sand, he won the 50- and 100-mile races.

All the races at Pendine Sand were stopped during a few years, for security reasons. They re-started on 2010.

In 2013, Brough Superior arrived with a replica of the SS100 Pendine, driven by Eric Patterson. The event was immortalized by Henry Cole.

The legend continues.



Pendine Sand racer is a refined and fascinating model as its big sister the SS100. One more word characterizes it as "captivating".

The most famous English motorcycle brand is now manufactured near Toulouse.

Pendine Sand racer means a lot.

Majestic exhausts pointed towards the sky. A 997cm³ twin engine, imagined with the French company Akira, developing 100 horsepower and 9.1 mkg. A Double-wishbone Fior front axle, worked like a silverware piece, for precise guidance and damping. a Braking system composed of a 320mm pads' duo with 4-piston radial calipers from Beringer, underlining French excellence. A last thing but not the least one, Aluminum swingarm and fork, exceptional pieces, entirely pruned from the mass.

The moto is available in two versions S for Sport and D for Desert.

Pendine, the sand panther that will put a spell on you.







TECHNICAL SPECIFICATIONS

ENGINE

Engine	997cc watercooled dohc 88° V-twin four-stroke with four valves per cylinder and composite chain / gear cam drive
Dimensions	94 mm x 71.8 mm
Power	102bhp (75kW) @9600rpm Euro 4 Homologation
Maximum torque	87Nm (64lb-ft) @7300rpm
Compression ratio	11 : 1
Fuel / Ignition system	Electronic fuel injection with Synerject ECU and 2 x 50 mm Synerject throttle bodies, each with a single injector
Gearbox	6-speed
Clutch	Multiplate oil-bath clutch with hydraulic operation

CHASSIS

Frame type	Machined Titanium frame with Titanium subframe and triangles
Front suspension	Fior-type Aluminium casting fork with twin articulated triangular Titanium links and Pre load and rebound adjustable monoshock with 120mm travel
Rear suspension	Machined Aluminium swingarm pivoting in engine crankcases, with preload and rebound Pre load and rebound adjustable monoshock
Head angle / Trail	24.8° with 108mm trail via 38mm fork offset
Front brake	2 x 320mm Beringer Stainless Steel discs with 2 x two-piston Beringer radial calipers
Rear brake	1 x 230mm Beringer Stainless Steel disc with 1 x two-piston Beringer radial caliper
Wheels	Machined aluminium wheels (16 spokes)
Front tyre	120/70 - 19" on 3.50 inches
Rear tyre	170/60 - 17" on 4.5 inches
Weight / Distribution	186 Kg (410 lb) split 50/50%

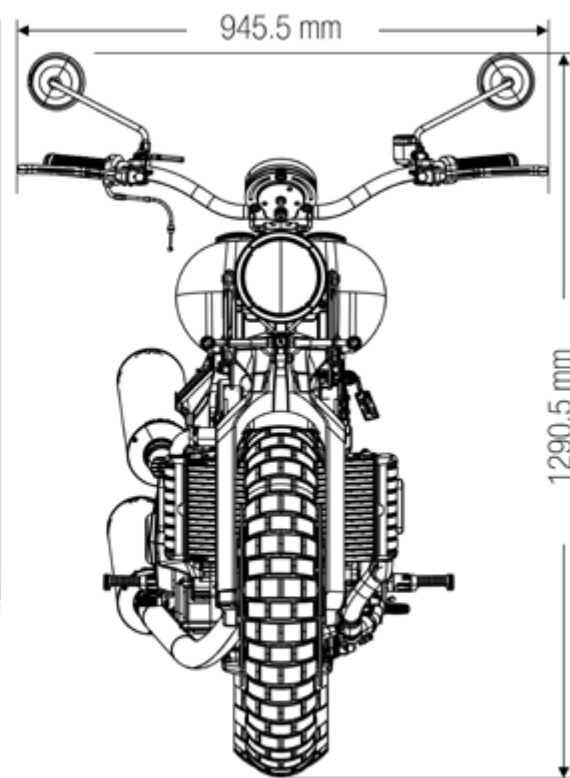
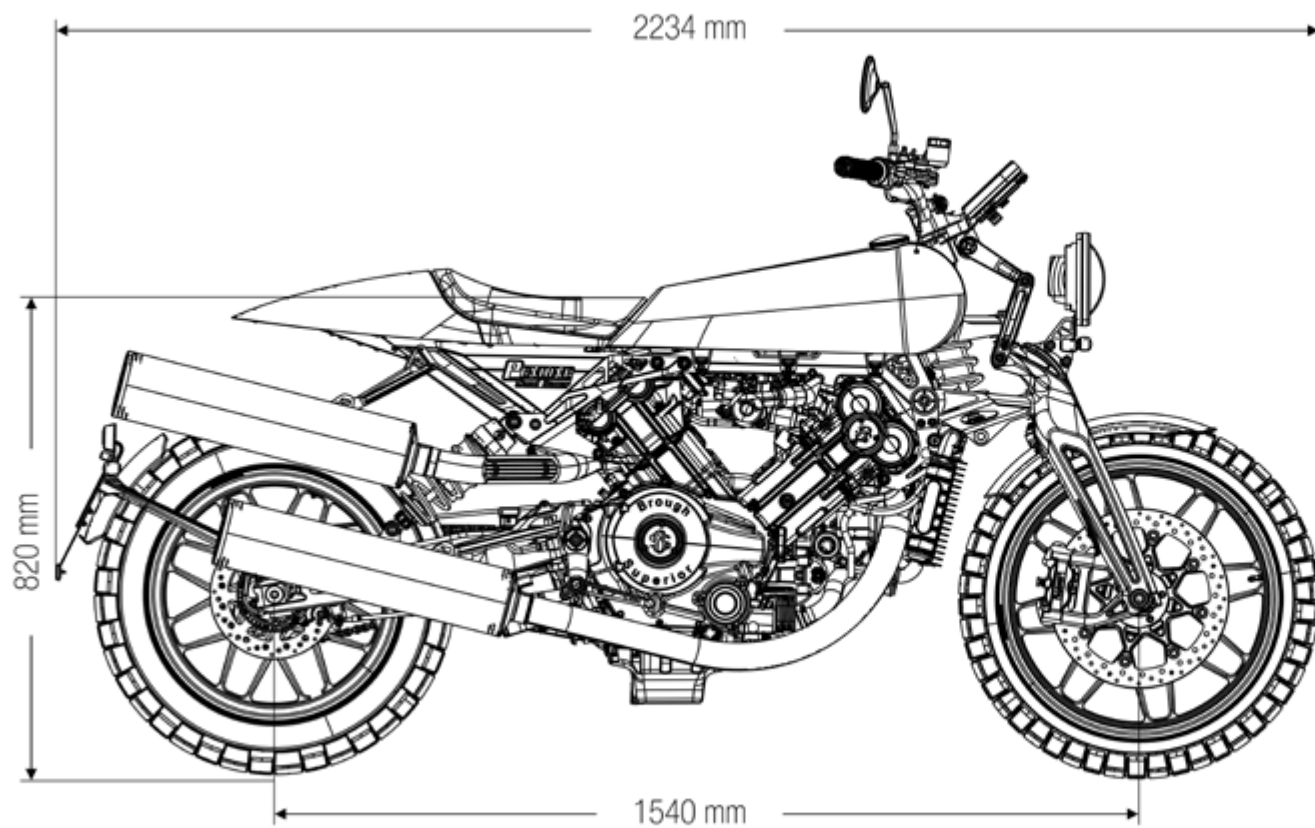





IMPORTANT NOTICES

Visuals: Photos and drawings

Some motorcycles are equipped with optional elements for racetrack use only. Additional options may be available at an additional cost. They may not be included in this brochure. Feel free to ask for more information.

Updates

In a process of constant improvement, both in terms of products (design, manufacturing, etc.) and safety, Brough Superior Motorcycles reserves the right to make changes to its product at any time, without notice. All specifications, illustrations, details and diagrams contained in this brochure are based on information available as of 07/06/2019.

Due to the limitations of printing process, visuals colors (if any) are not contractual.

Some images used for staging our product are not contractual.

Acceleration and speed rates may vary from those in the documentation depending on country specificities or product updates that may have occurred after documentation printing.

If you have any questions, please do not hesitate to contact your authorized Brough Superior Motorcycles contact person or feel free to contact us directly.

Copyright and other intellectual property rights

Copyright Brough Superior Motorcycles 2019. Do not reproduce or transmit without the express permission of Brough Superior Motorcycles. The Brough Superior name and logo are registered trademarks owned by Brough Superior Motorcycles Ltd and Brough Superior Motorcycles sas.

Company details

Brough Superior Motorcycles Head Office

20 rue Jean Monnet,

31240 Saint-Jean,

France.

Telephone +33 (0) 562 892 460

VAT number FR1801344318



www.broughsuperiormotorcycles.com
BROUGH SUPERIOR™ - ELF exclusively recommended lubricant
ELF is a registered trademark of the Total Group



BROUGH SUPERIOR MOTORCYCLES SAS  20 RUE JEAN MONNET 31240 SAINT JEAN (FRANCE)  +33 (0) 562 892 460